

Tiger II

Compact retail scales



Large easy to read digits

Robust construction

Up to 100 PLU

Up to 12 preset keys

Up to 30kg capacity



32 keys

Easy to use card for presets

Two PLU's can be linked to each preset key



Clear customer display

METTLER TOLEDO

Tiger II - Compact retail scale

Model without Tower	RN10-3S-CNRS	RN10-6S-CNRS	RN10-15S-CNRS	RN10-30S-CNRS
Model with Tower	-	RN10-6S-CNTRS	RN10-15S-CNTRS	RN10-30S-CNTRS
Capacity	3kg	6kg	15kg	30kg
Resolution	1g	2g	5g	10g
Minimum weight	20g	40g	100g	200g
Weigh plate size	342 x 242mm	342 x 242mm	342 x 242mm	342 x 242mm
Operating temperature	-10°C ~ +40°C	-10°C ~ +40°C	-10°C ~ +40°C	-10°C ~ +40°C
Storage temperature	-20°C ~ +50°C	-20°C ~ +50°C	-20°C ~ +50°C	-20°C ~ +50°C



Price computing scale

Performance

- 100g facility
- Auto zero function
- Keyboard with 32 keys
- Tare key operation
- Zero key
- Fix key
- 12 presets (M1 - M12)
- 100 PLU
- Sleep mode
- RS232C interface
- Stainless steel platter: 240 x 342mm

Screen display

- 7 segment LCD
- Optional backlight available
- Weight display: 6 digits
- Price per kg: 6 digits
- Price to pay: 6 digits
- Smart battery indicator
- Adjustable display angle (RN10-CNT) only

Power supply

- Power operation via plug-in power supply 230VAC, 50HZ/12VDC
- Battery operation by 6 rechargeable NIHM batteries
- Charging current 500mA
- **Stand-by time***
 - 2800mAh ≈ 43hr
 - 5000mAh ≈ 166hr
 - 7000mAh ≈ 233hr



Options

- Tower (Not available on 3kg model)

Accessories

- PLU card
Part No: 71207240
- Car adapter cable
(To connect to car cigarette lighter)
Part No: 99440148

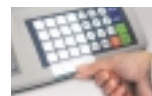

Application areas include:

- Mobile business
- Fruit and vegetable
- Meats and cheese
- Delicatessen
- Confectionery
- Coffee and tea
- Checkweighing
- ... and many more

* Stand-by time depends on the age and the charging condition of the used NIHM. The stated values given for new and completely charged NIHM.

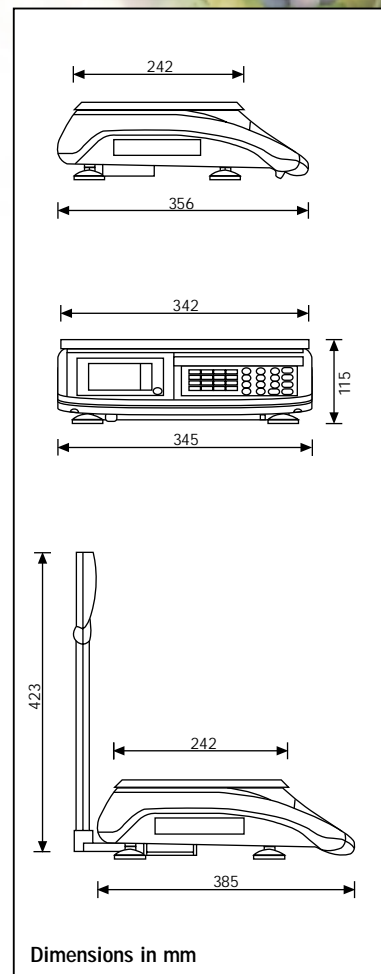

Your local dealer is:



CE Conformité Européenne



Quality certificate ISO 9001

Environment certificate ISO 14001



Mettler-Toledo Ltd
64 Boston Road, Beaumont Leys, Leicester LE4 1AW
Tel: 0116 235 7070 Fax: 0116 236 5500
Website: www.mt.com