

Reliable Performance

Powerful Features

Comprehensive Coverage



8442 Dot-matrix Integrated Scale/Printer

METTLER TOLEDO

The New 8442 Series Economical, User-friendly, Reliable

● Easy Access to Printer

The easy "slide out" access to the printer mechanism increases efficiency and reduces downtime during the label loading process.



The 8442 is packed with performance that significantly overshadows the minimal cost of ownership. Designed for today's supermarkets, delis and other retailers, it is loaded with features which make it an ideal solution for service counters and prepack areas.

With built-in prepack functionality, the 8442 is also well-suited for distribution center applications.

- Stainless steel printer mechanism
- Ethernet connectivity
- Prepack function
- Bright dual dot-matrix display

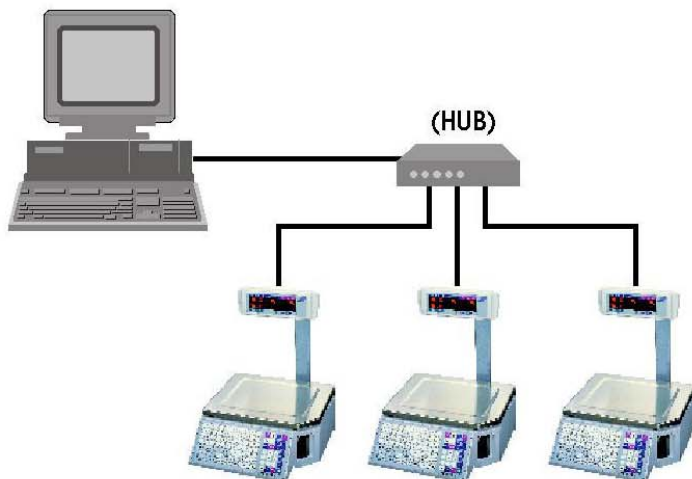

● Ethernet Connectivity

The new 8442 scale models are networkable within your existing TCP/IP network. Using the user-friendly PC based software, retailers can manage their fresh product data easily, improving efficiencies, and resulting in far fewer pricing errors.



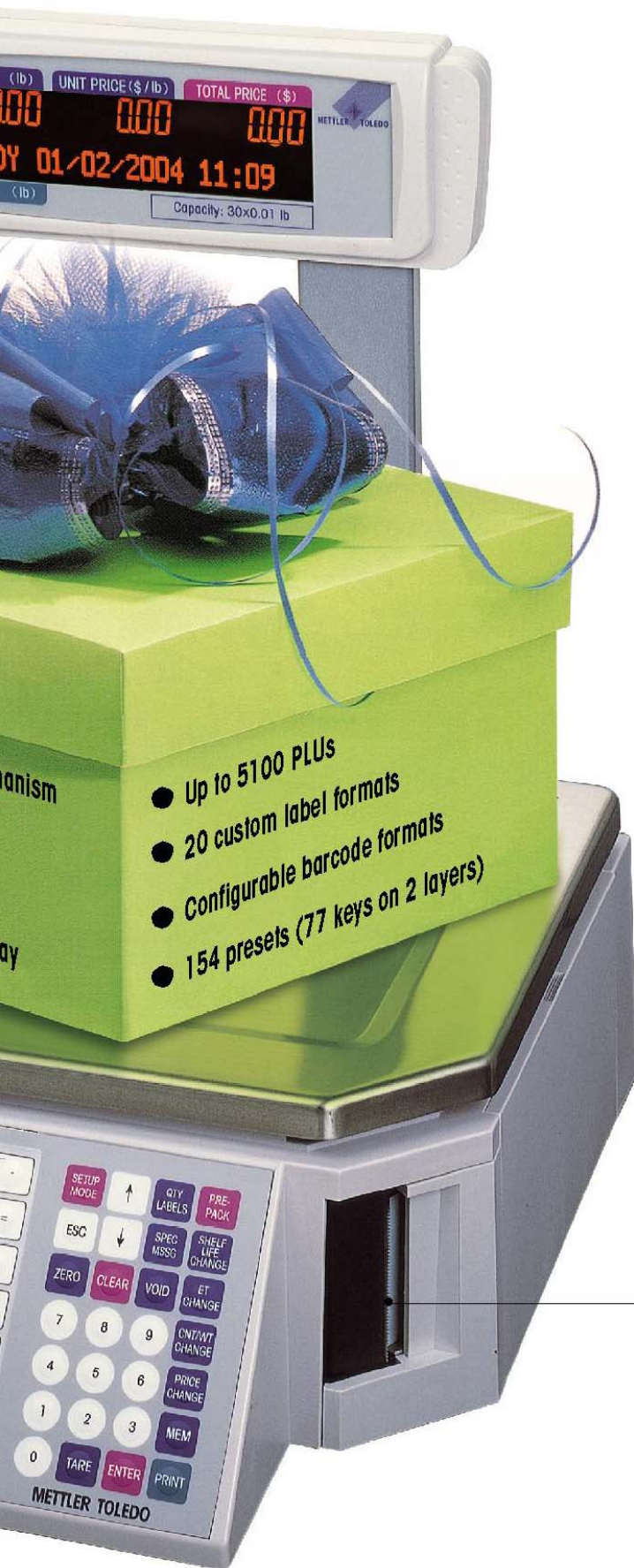

● **Dual Dot-matrix LCD Display**

The bright LCD display with adjustable contrast provides clear and attractive readings for operators and customers at all times. The large dot matrix display area allows for additional marquee messages boosting sales.



● **Flexible Label Formats**

The flexible and easy to use label design software allows you to design and format your own labels easily, offering the ability to specifically market to your unique clientele.



Product Features and Specifications

DISPLAY

- Dual reversed LCD display
- Weight, Tare, and Unit Pricing display
- 24 character dot-matrix display
- Adjustable contrast levels

MEMORY

- Up to 5100 PLUs
- Up to 1000 ingredient records
- 99 merchandising messages
- 8 configurable barcodes
- Marquee message

PRINTER

- Stainless steel printer mechanism
- Ticket / Label Printing
- Speed: 85mm/sec (3.5in/sec)
- Programmable UPC/EAN13 barcode
- Durable long lasting printhead
- Easy to load printer mechanism
- Open, easy to clean design

CAPABILITY

- Service counter or prepack mode
- Host PC communications to maintain data integrity
- Upgradeable flash memory for easy software updates

LABEL

- Width: 40~62mm (1.6"~2.4")
- Standard label lengths supported: 1.9", 2.1", 2.4", 3.3", 3.7"
- Custom label lengths: 20mm~102mm (0.8"~4.0")
- Label Roll: Max outside diameter: 120mm (4.7")
- Label Roll Core: Inside diameter: 40mm (1.6")
- 29 pre-programmed label formats
- Up to 20 custom label formats
- Printable fields: unit price, total price, weight, barcode, product description, pack date, sell by date, store name, special text, item number, PLU number, label number, etc.

KEYBOARD

- 28 function keys
- 154 presets (77 keys on two layers)

INTERFACES

- RS232 serial port
- Standard Ethernet interface (TCP/IP)

DIMENSIONS IN: INCH(MM)

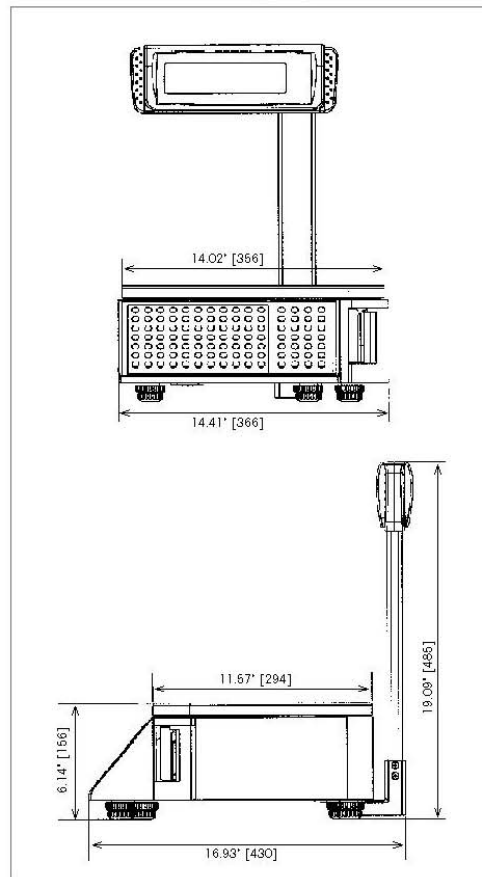

Quality Certificate
Development, production, testing of this
product according to the ISO9001/NO.
0197A015 & the ISO14001/NO.06-2000-052

Models	Description	Resolution	Min Cap
8442-1611-000	30 lb, US Version	0.01 lb	0.20 lb
8442-3611-089	6/15 kg, Canada dual-interval	2/5g	40g

For more information visit:

www.mt.com/retail

Mettler-Toledo, Inc.

USA & Canada

1900 Polaris Parkway Columbus, Ohio 43240

Tel: (800) 786-0038

Fax: (614) 438-4783

Fresh Solutions for Retail

Authorised Distributor: